



# FILL-RITE®

A GORMAN-RUPP COMPANY

## FR311VB SERIES TECHNICAL SPECIFICATIONS

### Motor

Power - AC 115, 230, 115/230	115/230
HZ 50, 60, 50/60	60/50
Power - DC 12, 24, 12/24	N/A
HP (horsepower) rating	¾ HP
Power cord length	N/A
Power cord gauge	N/A
Power cord DC battery connectors	N/A
Amps (FLA)	9.8/4.9 11.4/5.7
RPM	1725/1425
Duty cycle	30 min.
Thermal protection switch	Yes
Circuit protection fuse	None
Certification	UL, cUL

### Pump

Type - rotary, diaphragm, gear, vane	Rotary vane
GPM in supplied configuration	28.7
GPM open flow - no hose or nozzle	34.3
By-pass pressure rating (psi) - Max	26 psi
Dry vac (in Hg)	14
Head- Max	60.06
Anti-siphon valve	Anti-Siphon Ready
Inlet - Size / Thread	1.25"
Outlet - Size / Thread	NPT
Mount	Bung (NPT)
Materials of construction - pump housing	Cast Iron
Materials of construction - wetted material	Buna
Rotor materials of construction	Iron/Copper
Rotor vane material of construction	Carbon
Compatible fluids	Diesel, Gasoline, Bio-Diesel up to B20, E15, Kerosene
Strainer mesh size	40 x 40 x .008"
Warranty	Limited Lifetime Warranty*

SKU/Kit #	Small Pump Kits	Consists of:
KIT300BD	Bio-Diesel	Special Shaft Seal Assembly, Gasket, Inlet Gasket, Bypass O-ring
KIT300BV	Bypass	Poppet, Spring, O-ring, Cap
KIT300JC	Junction Box	Junction box cover, O-ring, hardware
KIT120NB	Nozzle Boot	Nozzle boot, attaching hardware
KIT300NR	Nozzle Retainer	Nozzle retainer and attaching hardware
KIT700BG	Inlet	Inlet adapter, AST 2 x 1 ¼"
KIT300SW	Switch Lever	Switch lever and nut
KIT300RG	Rotary Group	Rotor, 8 vanes, rotor key, gasket, rotor cover, 4 screws
KIT300SL	Shaft Seal	8 piece assembly
KIT300OT	Outlet	Outlet flange, O-ring seal, attaching hardware
KIT700AS	Anti-Siphon	Anti-siphon valve, Teflon tape, elbow adapter, stainless steel braided hose, attaching hardware

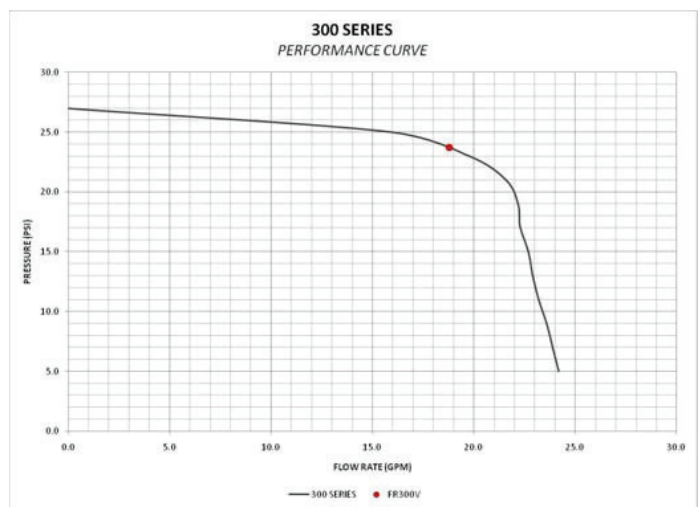

\*Warranty details can be found at fillrite.com

# FILL-RITE®

A GORMAN-RUPP COMPANY

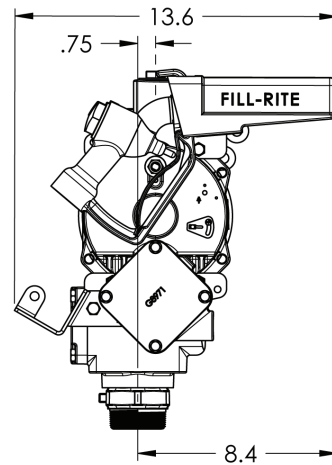
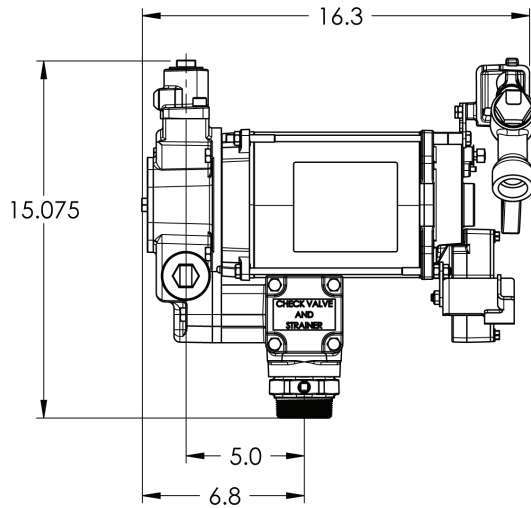
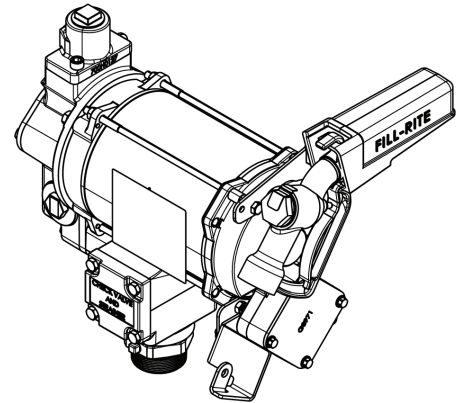
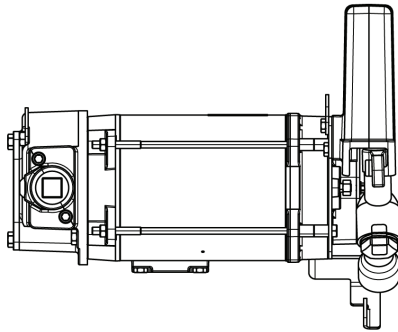

## Accessories

Suction pipe material	N/A
Suction pipe length	N/A
Nozzle size	1"
Nozzle - manual / automatic	Manual
Hose liquid materials compatibility	Black Nitrile Rubber
Hose diameter	1"
Hose length	18'
Hose static wire (Y/N)	Yes
Certifications	UL, cUL

## Measurements

Height	19.4"
Width	17"
Depth	17"
Intake Center Line to Discharge Center Line	2"
Intake Center Line to Back of Nozzle Boot	8.5"
Shipping Weight	94 lbs
Qty per Pallet	8
Box Dimensions	Length - 21"
	Width - 20"
	Height - 17"

**MADE IN USA**  
WITH GLOBAL MATERIALS

CUSTOMER SUPPORT: (800) 634-2695  
TECHNICAL SUPPORT: (260) 747-7524

[FILLRITE.COM](http://FILLRITE.COM)

**GR**  
GORMAN-RUPP  
COMPANY